

Code No: 09A10591

R09

**B. Tech I Year Examinations, May/June -2012**  
**ENGINEERING DRAWING**

(Common to Computer Science & Engineering, Production Engineering (Mechanical))

**Time: 3 hours**

**Max. Marks: 75**

**Answer any five questions**  
**All questions carry equal marks**

---

1. a) Draw a parabola using 'tangent method' with its base equal to 180 mm and axis equal to 70 mm.  
b) A room of  $1728 \text{ m}^3$  volume is shown by a cube of 4 cm side. Find the R.F. and construct a scale to measure up to 50 m. Also indicate a distance of 37.6 m on the scale. [15]
2. The front view of a line PQ is 60 mm long and makes  $45^\circ$  with the reference line. The end P is 10 mm above the H.P. and the V.T. of the line is 15 mm below the H.P. If the line PQ is inclined at  $30^\circ$  to the V.P., draw its projections. Determine its true length, inclination with the H.P. and locate its traces. [15]
3. a) A circular plane with a 60 mm diameter is resting on a point of its circumference on the V.P. The center is 40 mm above the H.P. and the surface is inclined at  $45^\circ$  to the V.P., and perpendicular to the H.P. Draw its projections.  
b) A hexagonal pyramid, having base with a 30 mm side and 70 mm long axis, has a triangular face on the ground and axis parallel to V.P. Draw its projections. [15]
4. A square prism, having a base with a 40 mm side and a 60 mm long axis, rests on its base on the H.P. such that one of its rectangular faces makes an angle of  $30^\circ$  with the V.P. It is cut by a section plane perpendicular to the H.P. and inclined at  $60^\circ$  to the V.P. passing through the prism such that the face which makes  $60^\circ$  with the V.P. is bisected. Draw its sectional front view, top view and true shape of section. [15]
5. A vertical cylinder with an 80 mm base diameter and a 130 mm long axis, is resting on its base in the H.P. It is penetrated by another cylinder with a 50 mm base diameter and 150 mm long axis. The axes of both the cylinders are parallel to the V.P. and bisect each other at an angle of  $30^\circ$ . Draw their projection and show the curves of intersection. [15]
6. A cone is placed centrally on the top of a cube with a 40 mm side which is placed centrally over a cylindrical block. The cone has a 30 mm base diameter and a 40 mm axis. The cylindrical block has an 80 mm base diameter and 10 mm thickness. Draw isometric projection of the arrangement. [15]

7. Draw the Front View, Top View and Right Side View for the following figure. [15]  
 (All dimensions are in mm)

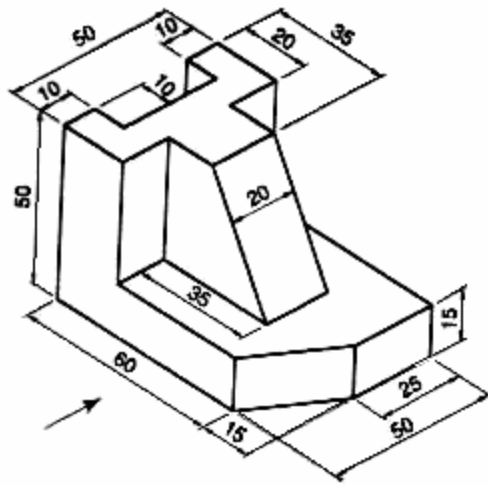

8. Draw a perspective view of a square prism having base with a 40 mm side and 60 mm long axis, resting on its base in the GP with its axis that is 40 mm behind the PP and a vertical face right to the axis inclined at  $60^\circ$  to it. The station point is 50 mm in front of PP, 90 mm above GP and lies in a CP which is 50 mm towards right of the axis. [15]

\*\*\*\*\*